

Load Rating Chart

Model SC85



© Manitex

NOTE: *Additional copies of this Load Rating Chart can be purchased from your Manitex Distributor. When ordering, use the part number shown in the bottom left corner of this page.*

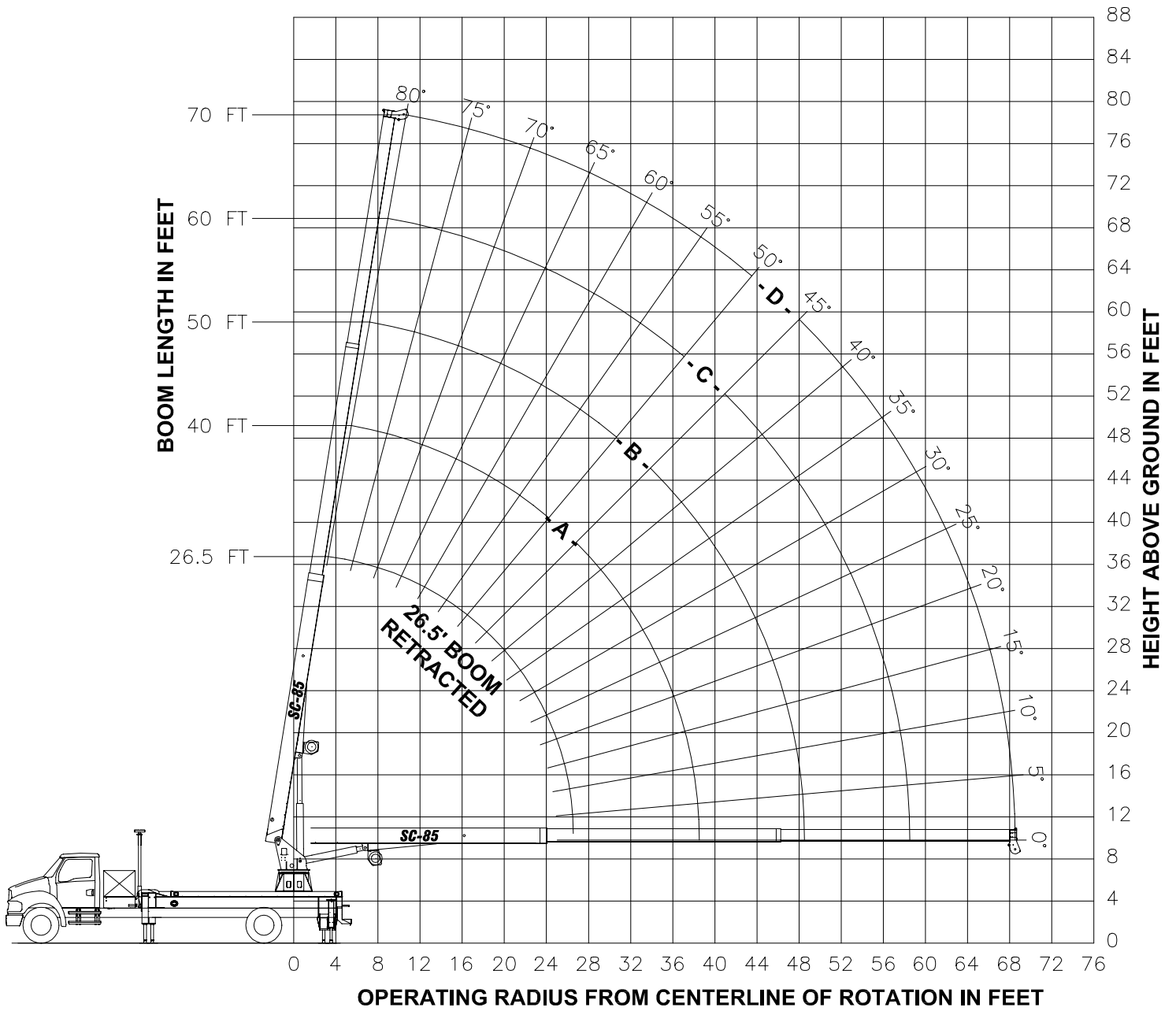

**RANGE DIAGRAM
- FOR CRANE OPERATION ONLY -
(MEETS ANSI B30.5 REQUIREMENTS)**

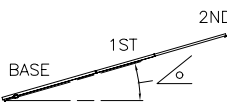

LOAD CHART
-FOR CRANE APPLICATION ONLY-
 (MEETS ANSI B30.5 REQUIREMENTS)

MAIN BOOM LOAD RATINGS IN LBS										
OPERATING RADIUS	LOADED BOOM ANGLE		BOOM LENGTH AND MARKER							
	°	26.5 FT	°	40 FT	°	50 FT	°	60 FT	°	70 FT
5	78	24000								
8	71	17030	78	15840						
10	67	14380	75	13230	78	12740				
12	62	12480	72	11370	76	10900	79	10570		
14	57	11040	69	9990	73	9520	77	9200	79	8960
16	51	9880	66	8910	71	8460	75	8140	78	7900
18	45	8910	63	8040	69	7600	73	7290	76	7060
20	38	8040	59	7320	66	6900	71	6600	74	6370
24	18	6180	52	6180	61	5810	67	5530	71	5310
28			44	5300	55	5000	62	4730	67	4520
32			35	4540	49	4350	58	4120	64	3920
36			22	3730	43	3800	53	3620	60	3440
40					35	3320	48	3200	56	3040
44					26	2820	43	2830	52	2700
48					10	2060	36	2490	47	2400
52							29	2150	42	2140
56							19	1730	37	1890
60									31	1640
64									23	1360
68									9	900
72										

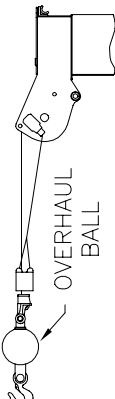

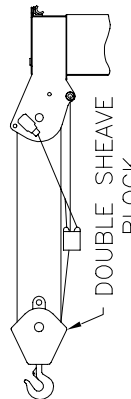
ALLOWABLE LINE PULL				WARNING
1 PART LINE	2 PART LINE	3 PART LINE	4 PART LINE	
				<p>ANTI-TWO BLOCK SYSTEM MUST BE IN GOOD OPERATING CONDITION BEFORE OPERATING THE CRANE.</p> <p>REFER TO THE OWNER'S MANUAL.</p> <p>KEEP AT LEAST 3 WRAPS OF LOAD LINE ON DRUM AT ALL TIMES.</p>
5840 LBS	11680 LBS	17520 LBS	23360 LBS	1/2" ROT RESISTANT (5:1 SF) 29200 LB MIN BREAKING STRENGTH
6000 LBS	12000 LBS	18000 LBS	24000 LBS	1/2" 6 X 25 IWRC (3.5:1 SF) 23000 LB MIN BREAKING STRENGTH

DEDUCTIONS FROM RATED LOADS FOR LOAD HANDLING DEVICES SUPPLIED BY MANITEX

OVERHAUL BALL — — — — — SEE OVERHAUL BALL MANUFACTURER NAMEPLATE
 LOAD BLOCKS — — — — — SEE BLOCK MANUFACTURER NAMEPLATE
 2-MANBASKET SLR PLATFORM — — — — — 700 LBS

WARNING

1. THE OPERATOR MUST READ AND UNDERSTAND THE OWNER'S MANUAL BEFORE OPERATING THIS CRANE.
2. POSITIONING OR OPERATION OF CRANE BEYOND AREAS SHOWN ON THIS CHART IS NOT INTENDED OR APPROVED EXCEPT WHERE SPECIFIED IN OWNER'S MANUAL.
3. LOADED BOOM ANGLES AT SPECIFIED BOOM LENGTHS GIVE ONLY AN APPROXIMATION OF THE OPERATING RADIUS. THE BOOM ANGLE BEFORE LOADING SHOULD BE GREATER TO ACCOUNT FOR DEFLECTIONS. DO NOT EXCEED THE OPERATING RADIUS FOR RATED LOADS.
4. FOR BOOM ANGLES NOT SHOWN ON LOAD RATING CHART, USE RATING OF NEXT LOWER BOOM ANGLE.
5. FOR BOOM LENGTHS NOT SHOWN, USE RATING OF NEXT SHORTER OR LONGER BOOM LENGTH, WHICHEVER IS LESS. FOR RADII NOT SHOWN, USE RATING OF NEXT LONGER RADIUS.
6. CRANE LOAD RATINGS ON OUTRIGGERS ARE BASED ON FREELY SUSPENDED LOADS WITH THE MACHINE LEVELED AND STANDING ON A FIRM UNIFORM SUPPORTING SURFACE. NO ATTEMPT SHALL BE MADE TO MOVE A LOAD HORIZONTALLY ON THE GROUND IN ANY DIRECTION.
7. PRACTICAL WORKING LOADS DEPEND ON SUPPORTING SURFACE, WIND, AND OTHER FACTORS AFFECTING STABILITY SUCH AS HAZARDOUS SURROUNDINGS, EXPERIENCE OF PERSONNEL, AND PROPER HANDLING, ALL OF WHICH MUST BE TAKEN INTO ACCOUNT BY THE OPERATOR.
8. THE MAXIMUM LOAD WHICH MAY BE TELESCOPED IS LIMITED BY HYDRAULIC PRESSURE, BOOM ANGLE, AND BOOM LUBRICATION. IT IS SAFE TO ATTEMPT TO TELESCOPE ANY LOAD WITHIN THE LIMITS OF THE LOAD RATING CHART.

INFORMATION

1. DEDUCTIONS MUST BE MADE FROM RATED LOADS FOR OPTIONAL ATTACHMENTS, HOOKS, AND LOADBLOCKS (SEE DEDUCTION CHART). WEIGHTS OF SLINGS AND ALL OTHER LOAD HANDLING DEVICES SHALL BE CONSIDERED A PART OF THE LOAD.
2. CRANE LOAD RATINGS WITH OUTRIGGERS ARE BASED ON OUTRIGGERS AND STABILIZERS EXTENDED AND SET WITH MACHINE LEVELED.
3. LOAD RATINGS ABOVE THE HEAVY LINE ARE STRUCTURALLY LIMITED CAPACITIES. LOAD RATINGS BELOW THE HEAVY LINE ARE STABILITY LIMITED CAPACITIES AND DO NOT EXCEED 85% OF TIPPING.

DEFINITIONS

1. OPERATING RADIUS IS THE HORIZONTAL DISTANCE FROM THE AXIS OF ROTATION TO THE CENTER OF THE VERTICAL HOIST LINE OR TACKLE WITH LOAD APPLIED.
2. LOADED BOOM ANGLE AS SHOWN IN THE COLUMN HEADED BY \sphericalangle , IS THE INCLUDED ANGLE BETWEEN THE HORIZONTAL AND LONGITUDINAL AXES OF THE BOOM BASE AFTER LIFTING RATED LOAD AT RATED RADIUS.

MODEL SC85

SELF LEVELING ROTATING (SLR) PERSONNEL PLATFORM RANGE DIAGRAM

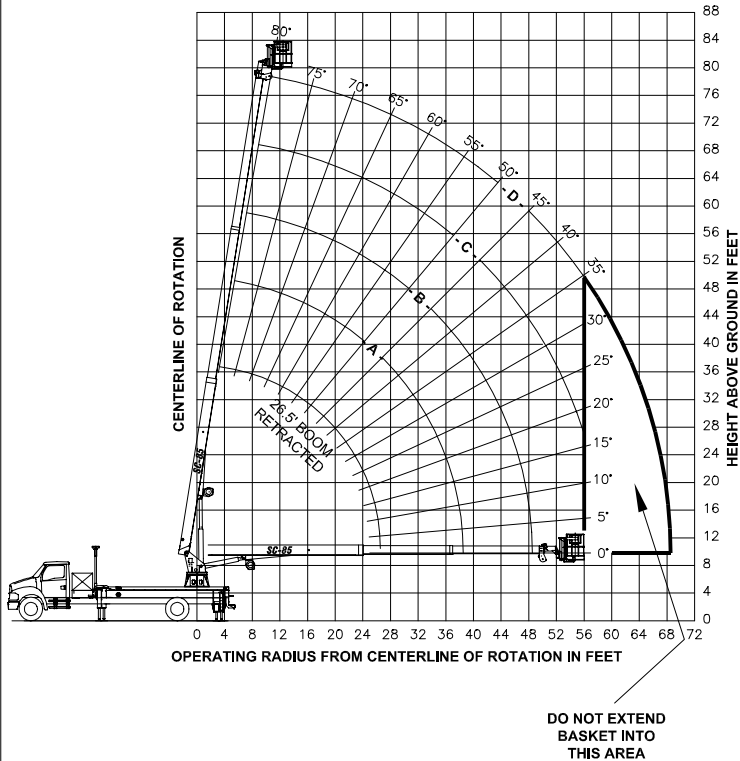

! DANGER

FAILURE TO READ, UNDERSTAND AND OBEY THE FOLLOWING INSTRUCTIONS CAN RESULT IN DEATH OR SERIOUS INJURY

MAXIMUM ALLOWABLE PLATFORM CAPACITY IS 600 LBS.

1. FOR CRANE STABILITY, LEVEL CRANE BY PROPERLY EXTENDING OUTRIGGERS ON A FIRM SURFACE. CRANE TIRES MUST BE JUST TOUCHING SURFACE.
2. THE MAXIMUM ALLOWABLE PLATFORM CAPACITY INCLUDES PERSONNEL, TOOLS LOAD SUSPENDED FROM THE JIB WINCH OR ANY OTHER EXTERNAL WEIGHT.
THE MAXIMUM ALLOWABLE PLATFORM CAPACITY MUST NEVER BE EXCEEDED. LOADS IN EXCESS OF THE MAXIMUM ALLOWABLE PLATFORM CAPACITY WILL AFFECT THE CRANE STABILITY OR STRUCTURAL INTEGRITY AND MAY CAUSE A FALL RESULTING IN DEATH OR SERIOUS INJURY.
3. ALWAYS USE BODY BELTS AND LANYARDS WHEN USING ANY PERSONNEL PLATFORM. FASTEN LANYARD HOOK TO BOOM TIP OR JIB ANCHOR POINT PROVIDED.
4. ALWAYS REMOVE OVERHAUL BALL OR SNATCH BLOCK AND SECURE LOAD LINE AT BOOM BASE ATTACHMENT BEFORE USING ANY PERSONNEL PLATFORM.
5. ANY PERSONNEL PLATFORM ON THIS MACHINE DOES NOT PROVIDE PROTECTION FROM CONTACT WITH OR PROXIMITY TO ELECTRICALLY CHARGED CONDUCTORS. DEATH OR SERIOUS INJURY WILL OCCUR IF ADEQUATE CLEARANCE IS NOT MAINTAINED.
REFER TO OPERATORS MANUAL FOR MINIMUM CLEARANCE REQUIRED BETWEEN ANY PART OF THE BOOM OR PLATFORM AND THE POWER LINE.
6. WHEN LOADING OR UNLOADING ANY PERSONNEL, FULLY RETRACT THE BOOM AT ANY ANGLE ABOVE 0 DEGREES, LOWER THE BOOM TO -15 DEGREES AND EXTEND THE BOOM UNTIL PLATFORM IS CLOSE TO GROUND.

AREA OF OPERATION

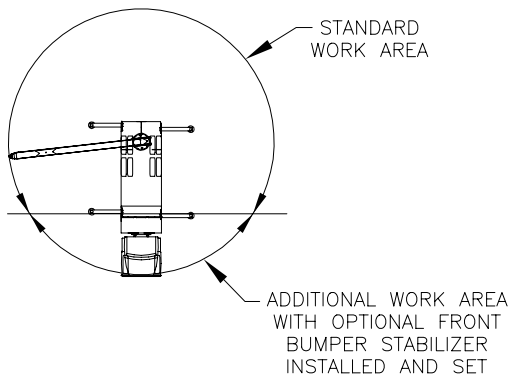

**Manitex
SkyCrane**

CRANE MEETS ANSI A92.2 REQUIREMENTS